

Self-Propelled Aerial Work Platform



- A compact machine with low overall weight.



Genie Runabout™

- The Runabout features Genie's **patented mast system** with high strength interlocking aluminum mast sections and heavy duty lifting chains.
- Narrow 29½ in (75 cm) width and 53 in (1.35 m) length **allow unit to fit in most passenger elevators.**
- Low 19 in (48 cm) entry height allows operators to enter the platform easily. **Unit can be driven through doorways with operator on board.**
- Optional platform extension deck provides 20 in (51 cm) of horizontal outreach.
- Standard non-marking tires and low unit weight **allow use on sensitive flooring.**

- Standard dual wheel spring-applied, hydraulically released braking system.
- **All models are driveable when fully elevated.** GR-8 and GR-12 models can be driven when fully elevated with the optional platform extension deck deployed. GR-15 can be driven when fully elevated with the optional extension deck retracted.

Standard Features

- 500 lb (227 kg) lift capacity on GR-8, GR-12; 350 lb (159 kg) lift capacity on GR-15
- 24V DC electric motor provides clean power for indoor use
- High battery amp hour rating provides prolonged usage between charges
- 25 amp automatic charger for easy overnight recharging
- Proportional drive controls
- 30% gradeability
- Standard platform with basic sliding midrail
- Fixed pothole protection
- Forklift pockets and tie-down points
- Non-marking solid rubber tires
- Descent and tilt alarms
- Workstation tray

Options and Accessories

- Platform extension deck with gated-entry platform
- Fluorescent tube caddy
- 1,000 watt inverter
- Mast guard (in lieu of workstation tray)

Standards Compliance

- ANSI/SIA A92.6
- CE compliance option
- AS 1418.10
- CSA - Call factory for details

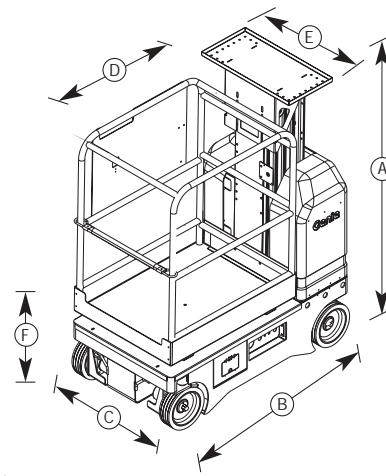

Specifications

Model	GR-8		GR-12		GR-15	
	US	Metric	US	Metric	US	Metric
Working height ¹	14 ft 4 in	4.54 m	17 ft 9 in	5.58 m	21 ft 2 in	6.62 m
Platform height	8 ft 4 in	2.54 m	11 ft 9 in	3.58 m	15 ft 2 in	4.62 m
(A) Height - stowed						
ANSI with workstation tray	67 ½ in	1.71 m	67 ½ in	1.71 m	67 ½ in	1.71 m
ANSI with mastguard	65 ½ in	1.66 m	65 ½ in	1.66 m	65 ½ in	1.66 m
CE with workstation tray	70 ½ in	1.79 m	70 ½ in	1.79 m	70 ½ in	1.79 m
CE with mastguard	70 ½ in	1.79 m	70 ½ in	1.79 m	70 ½ in	1.79 m
(B) Length	53 in	1.35 m	53 in	1.35 m	53 in	1.35 m
(C) Width	30 in	76 cm	30 in	76 cm	30 in	76 cm
(D) Platform length	37 in	94 cm	37 in	94 cm	37 in	94 cm
(E) Platform width	29 ½ in	75 cm	29 ½ in	75 cm	29 ½ in	75 cm
Platform length — extended	57 in	1.45 m	57 in	1.45 m	57 in	1.45 m
Platform extension length	20 in	51 cm	20 in	51 cm	20 in	51 cm
(F) Platform entry height	19 in	48 cm	19 in	48 cm	19 in	48 cm
Lift capacity	500 lb	227 kg	500 lb	227 kg	350 lb	159 kg
Extension deck capacity	250 lb	113 kg	250 lb	113 kg	250 lb	113 kg
Turning radius — outside	62 in	1.57 m	62 in	1.57 m	62 in	1.57 m
Turning radius — inside	6 in	15 cm	6 in	15 cm	6 in	15 cm
Power source	24V (4 6V 205AH batteries) (all models)					
Drive speed — stowed	2.5 mph	4 km/h	2.5 mph	4 km/h	2.5 mph	4 km/h
Drive speed — raised	0.5 mph	0.8 km/h	0.5 mph	0.8 km/h	0.5 mph	0.8 km/h
Raise/lower speed	15/20 sec		18/20 sec		20/20 sec	
Gradeability	30%		30%		30%	
Weight	1,450 lb	658 kg	1,650 lb	748 kg	2,150 lb	975 kg

¹ The metric equivalent of working height adds 2 m to platform height. U.S. adds 6 ft to platform height.

Distributed By:	Genie Industries
<p>GENIE UNITED STATES 18340 NE 76th Street P.O. Box 97030 Redmond, Washington 98073-9730 Telephone (425) 881-1800 Toll Free in USA/Canada 800-536-1800 Fax (425) 883-3475 http://www.genieindustries.com</p>	<p>GENIE UNITED KINGDOM The Maltings, Wharf Road Grantham Lincolnshire NG31 6BH England Telephone +44 (0)1476 584333 Fax +44 (0)1476 584334 http://www.genieindustries.com</p>